



ScanPal® 2

Features

- **128 x 64 dot Graphic LCD Display (backlit)**
- **CCD or Laser scan engine options**
- **1 MB for programs and 1 MB SRAM for data**
- **RS232, KBW, Infrared & IrDA interfaces**
- **Alkaline or NiMH rechargeable batteries**
- **Application generator and download software**



The ScanPal 2 is a portable data collection terminal with elegant styling. It is designed to provide high performance for all-day, everyday use. It is supported by a rich set of development tools, including 'C', 'BASIC' and a Windows-based application generator.

With its integrated Laser/LRCCD barcode scanning unit, the ScanPal 2 is ideal for inventory control, work-in-process tracking, shop floor management, asset tracking, meter reading, warehousing and distribution operations.



Accessories:

- Download/Charger Cradle.
- Dual battery pack charger (incl power supply).
- IR Transceiver.
- Protective case.
- KBW interface cable.
- Basic & 'C' development tools.



ScanPal® 2

OPERATIONAL

CPU	16-bit CMOS, low power consumption
Program memory	1 MB flash memory
Data memory	1 MB SRAM
Display	128 x 64 graphic dots FSTN with LED back-lit
Keypad	21 rubber keys
Indicator	Buzzer – Programmable, 1 KHz to 4KHz LED – Dual-color, green and red
Laser Scanner	Light source – Visible Laser diode operating at 670 ± 15 nm Scan rate – $36 \pm$ scans/sec Scan angle – 42° nominal
CCD Range	Depth of field – 5 cm - 95 cm, depends on bar code resolution Resolution – 0.125 mm - 1.00 mm Depth of field – 30 mm - 200 mm (for 0.33 mm label) Scan rate – 100 scans/sec
Communication	RS-232 – Transmission speed up to 115.2k bps, Keyboardwedge IrDA – Standard 1.0 compatible, up to 115.2k bps High speed IR – Up to 115.2k bps transmission rate
Programming Language	'C', 'BASIC', and a Windows-based Application Generator

MECHANICAL

Length	145 mm
Width	63 mm
Height	33.5 mm
Weight	180 g (including batteries)

ELECTRICAL

Power - Battery Operation	Two AAA size removable or rechargeable NiMH batteries
Power - Backup Battery	3.0V, 7.0mAh, rechargeable Lithium-ion battery
Operation	Over 100 hours (with Alkaline batteries)

ENVIRONMENTAL

Operating Temperature	0°C to 60°C
Storage Temperature	-30°C to 70°C
Humidity	Non-condensing 5% to 95%
Shock resistance	1.2m drop on to concrete
EMC regulation	FCC class-A, CE and C-Tick approved

ACCESSORIES

KBW cable, High speed IR Transceiver, Protective case, Dual battery pack charger, Download/Charger Cradle

RS-232 and IrDA Connection

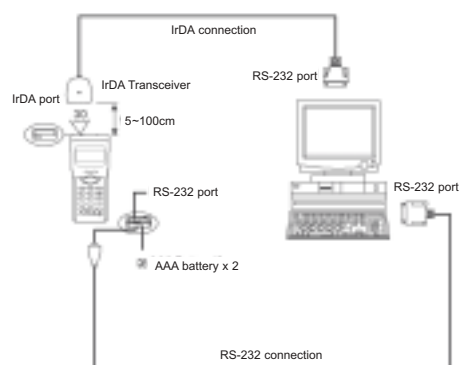

Dimensions

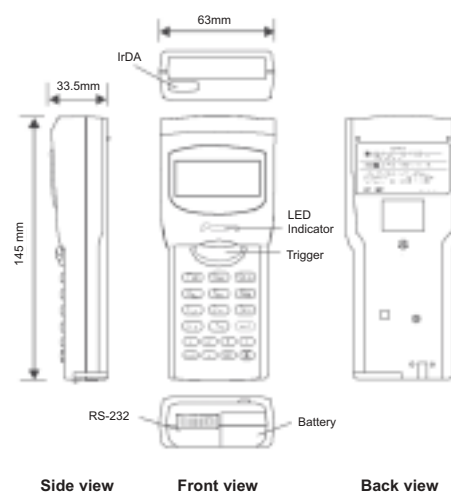

Specifications subject to change without notice.
Copyright April 2003.
Metrologic, All rights reserved.

EUROPEAN REGIONAL OFFICES

Eastern-Europe, Middle East & Africa
Metrologic Instruments GmbH
Tel: +49 (0) 89 89 019 222
Fax: +49 (0) 89 89 019 173
Email: info@east.metrologic.com
www.europe.metrologic.com

France
Metrologic Eria France SA
Tel: +33 (0) 1 48.63.78.78
Fax: +33 (0) 1 48.63.24.94
Email: info@fr.metrologic.com
www.europe.metrologic.com

Germany
Metrologic Instruments GmbH
Tel: +49 (0) 89 89 019 0
Fax: +49 (0) 89 89 019 200
Email: info@de.metrologic.com
www.metrologic-instruments.de

Italy
Metrologic Instruments Italia Srl
Tel: +39 0 51 6511978
Fax: +39 0 51 6521337
Email: info@it.metrologic.com
www.metrologic.it

Spain
Metrologic Eria Ibérica SL
Tel: +34 (91) 327 24 00
Fax: +34 (91) 327 38 29
Email: info@es.metrologic.com
www.metrologic.es

United Kingdom
Metrologic Instruments UK Ltd
Tel: +44 (0)1256 365900
Fax: +44 (0)1256 365955
Email: info@uk.metrologic.com
www.metrologic.co.uk

USA
Metrologic Instruments, Inc.
Tel: 1-800-ID-METRO
Fax: 1-856-228-6673
Email: info@metrologic.com

South America
Metrologic South America
Tel: 5511-5505-6568
Fax: 5511-5505-1681
Email: info@sa.metrologic.com

Brazil (only)
Metrologic do Brasil Ltda.
Tel: 5511-5505-2396
Fax: 5511-5507-2301
Email: info@br.metrologic.com

Asia
Metrologic Asia (Pte) Ltd.
Tel: 65-842-7155
Fax: 886-3-2888292
Email: info@sg.metrologic.com

China (only)
Metro (Suzhou) Technologies Co.Ltd
Tel: 86-512-2572511
Fax: 86-512-2571517
Email: info@cn.metrologic.com

Metrologic®
IDENTIFYING SOLUTIONS